

LITES & LOUVERS



CANADIAN GEESE - The Canadian goose is the most recognizable goose in North America. Its black and white head and characteristic “honking” call make the Canadian goose an easily identifiable bird. They are known to take up residence in urban environments and to discontinue migrating if conditions are acceptable.



Lites & Louvers Product Index:

Lite Kits

Page

Aluminum	L16A
False Mullion	L9
Low Profile	L4-L7
Round	L22
Security	L17-L21
Security Grille	L13-L15
Sound-rated	L5
Square profile	L8-L12
Stainless Steel	L16
Thru-bolted	L12

Louvers



Page

Aluminum	L25
Dark Room	L28
Fire-rated	L26
Security Grille	L27
Steel	L23-L24

**Numerical Index:**

Model	Lite Kits	Page
L-CVFM-SS	Stainless Steel	L16
L-FRA100	Low Profile	L4
L-FRA100-ALUM	Aluminum Lite Kit	L16A
L-FRA100-RD	Round Low Profile	L22
L-FRA100-SP	Low Profile Special Glass or Door Thickness	L6-L7
L-FRA100 STC	Sound Rated Low Profile	L5
L-FRA100-SP STC	Sound Rated Low Profile Special Glass or Door Thickness	L5
L-GLF100	Square Profile	L8
L-GLF100-SP	Square Profile Special Glass or Door Thickness	L10-L11
L-GLF100-SP-TB	Thru-Bolted Special Glass or Door Thickness	L12
L-GLF100-TB	Thru-Bolted	L12
L-SG100	Security Grille	L13, L15
L-SG100-TB	Security Grille Thru-Bolted	L14-L15
L-VGLF-MD, MDL	Security Grille with Privacy Panel	L19
L-VGLF-OG	Security Glass with Privacy Panel	L20
L-VGLF-PZ	Security Glass	L18
L-VGLF-SF	Security Grille with Privacy Panel	L21
L-VGLF-WD	Security Glass with Privacy Panel	L17
Options: G2-G24	False Mullion	L9
Model	Louvers	Page
L-75-A, B, BF	Dark Room	L29
L-A700-A, B, BF, C	Aluminum	L25
L-700-A, B, BF, C	Steel - Adjustable 1-3/8" to 2-1/4" doors	L24
L-700RX	Steel Self-Attaching	L23
L-1800	Adjustable Blade	L27
L-1900	Fire-rated Fusible Link	L26
L-VRSG-2	Security Grille	L28
L-VRSG-3	Security Grille (Both sides)	L28
L-Clips	H.M. Door Reinforcement	L30
Lite Kit and Louver Fasteners		L30

Rating Symbols Legend

-  **POSITIVE PRESSURE - CERTIFIED by UL to ANSI/UL10C;** complies with IBC, NFPA 80 and NFPA 252 for use on Hollow metal fire doors rated up to 3 hours and Wood fire doors rated up to 90 minutes (some ratings vary as noted).
-  **CERTIFIED by UL to CAN/ULC-S104 and ANSI/UL10B;** complies with NFPA 80 and NFPA 252 for use on Hollow metal fire doors rated up to 3 hours and Wood fire doors rated up to 90 minutes (some ratings vary as noted).

Materials

Lite Kits are available in Cold Rolled Steel, Galvanneal Steel, and Stainless Steel (type 304). Louvers are available in Cold Rolled Steel, Galvanneal Steel, and Aluminum Alloy 6063-T5.

Powder Coat Finish

The standard finish for each product is indicated on the catalog page and in the price list and will be provided unless one of the following optional finishes is indicated. See www.ngp.com for color chart:

- | | |
|-----------------------|--|
| (GPZ) Gray Primer | (BPR) Beige Primer (matches Steelcraft) |
| (DKB) Dark Bronze | (PTY) Putty (matches Anemostat Beige) |
| (T) Tan | (CAB) California Bronze (matches Anemostat) |
| (GBL) Gloss Black | (W) White |
| (MBL) Matte Black | (B) Brass (Gold) |
| (TBL) Textured Black | (WB) Walnut Brown (matches Timely Browntone) |
| (ASL) Aluminum Silver | (MW) Magnolia White (matches Timely Western White) |

Custom colors and color matching available – Consult customer service for details

Corrosion Resistant Sealer: A polymeric green seal (non-chrome) corrosion resistance extender is applied under all NGP powder coat finishes. Laboratory salt spray tests prove a dramatic increase in corrosion resistance on steel products with this sealer applied to the metal prior to the powder coat finish.

Salt Spray Test Results: Steel lite kits with NGP’s corrosion resistant sealer and powder coat finish withstood 1,248 hours without failing. This is 2-1/2 times longer than the protection provided by powder coating only.

Zinc Electro-Plating

Available on steel lite kits and louvers for extra corrosion resistance; recommended for exterior, wet areas, and coastal salt air locations. Zinc electro-plating will be applied prior to the powder coat finish. Specify on order “Zinc EL-Plate” and powder coat color desired. Not available on insect screen.

How to Order Example

Quantity	Model#	Finish	Cut-out Size (width x height)	Options
10	L-FRA100-SP	DKB	24" x 30"	for 1" thick glass

Lite Kit Technical Information

Fire-Rated Lite Kits: Lite Kits installed in fire-rated doors require fire-rated glass and glazing tape.

Impact Safety Rated Glass requirements: IBC requires all individual glazed areas in swinging doors to be impact safety-rated to comply with the CPSC 16CFR 1201 Category I or II.

Accessibility Standard Compliance:

ADA Standards for Accessible Design, requires that the bottom of the glass panel in a vision lite be located 43" maximum above the floor. An exception for vision lites with the lowest part more than 66" above the floor are not required to comply.

Louver Technical Information

Steel louvers over 46" wide and aluminum louvers over 36" wide must be furnished as two louver cores mounted in one louver frame with a mullion in between. All Louvers over 64" or more in height will be furnished as two louver cores mounted in one frame with a mullion in between.

LEED Green Building

The LEED (Leadership in Energy and Environmental Design) Green Building Rating System® is a national standard for developing high-performance, sustainable buildings developed by the U. S. Green Building Council. Our current LEED letter containing LEED qualification information for all our products is available at www.ngp.com

Environmental Product Declarations (EPD) prepared and certified by an Independent Laboratory based on Life Cycle Assessments (LCA) of our products may be viewed on our website www.ngp.com

Health Product Declarations (HPD) may be viewed on our website www.ngp.com

National Guard Products sustainability report may be viewed on our website www.ngp.com

Contact us regarding our end of use product recycling program.

Buy American Requirements

Buy American Act

Over 99% of our products are produced in the United States as a domestic construction material, as defined in the Buy American Act (BAA) of March 1933 and amended by the Buy American Act of 1988 and FAR 52.225-9. A Buy American certificate may be obtained on our website www.ngp.com

Federal American Recovery and Reinvestment Act

More than 99% of our products qualify as manufactured products produced in the United States as manufactured goods, as defined in OMB Guidance (176.140; 176.70(a) (2) (ii); 176.160, complying with the Federal American Recovery Reinvestment Act, ARRA-2009. Contact us for a Buy America ARRA certificate for your project.

Buy America

More than 99% of our products comply with Buy America Requirements of 49 U.S.C. 5323(j)(1), and the applicable regulations in 49 CFR part 661. Contact us for a Certificate of Compliance for your project.

Components of unknown origin are considered to have been produced or manufactured outside the United States.



L-FRA100

Low Profile Lite Kit for 1-3/4" Thick Doors and 3/16", 1/4" or 5/16" Glass

- 18 ga. cold rolled steel
- Mitered and welded corners
- Welded reinforcing clips at corners
- Counter-sunk mounting screw-holes
- #8 x 1-3/4" Phillips head SMS
- Available in uneven and fractional sizes
- Gray Primer (GPZ) powder coat finish

Available Options

- Powder coat color options - see page L2
- Torx Security Screws
- Galvanneal - A40 Steel
- Zinc electro-plating
- Glass & Glazing tape - See Glass Section
- Lead lining - .030" thick

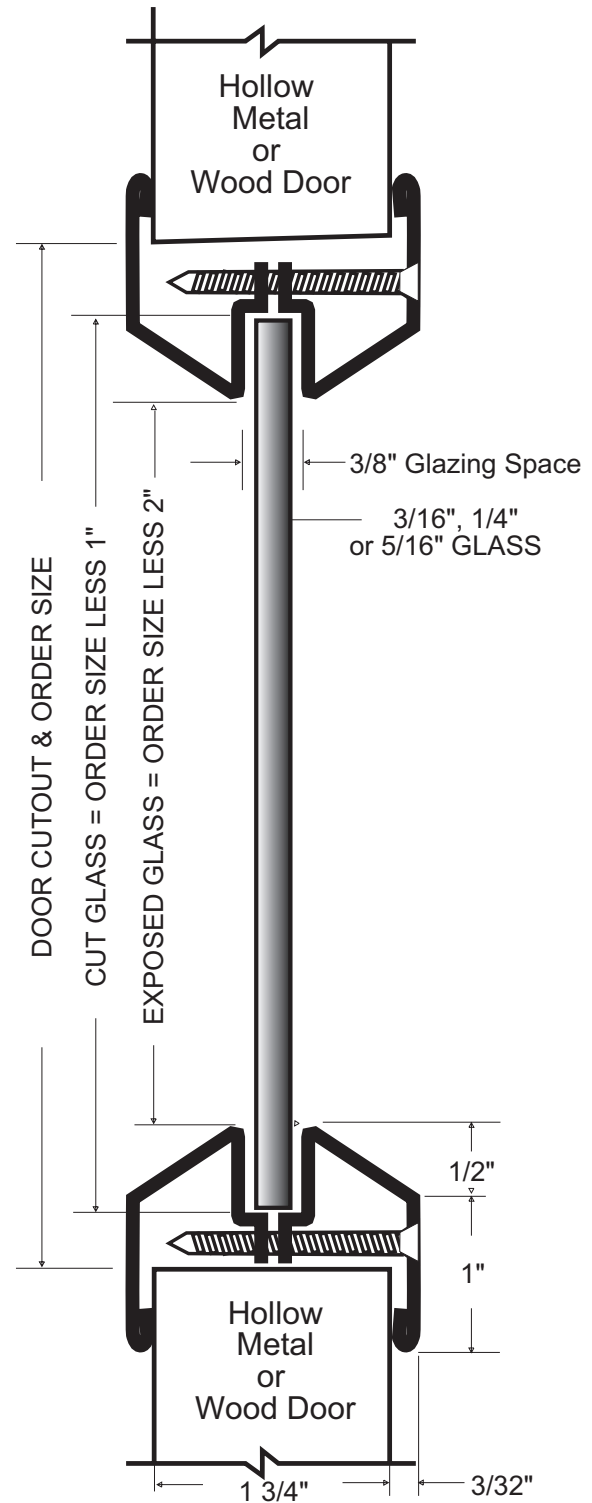

Designed for use on 1-3/4" thick doors manufactured within door industry tolerance of +/- 1/16".

L-FRA100 STC & L-FRA100-SP STC

Low Profile Sound Rated Lite Kit Option - Suffix "STC"

Silicone acoustical seal applied to reduce sound transmission

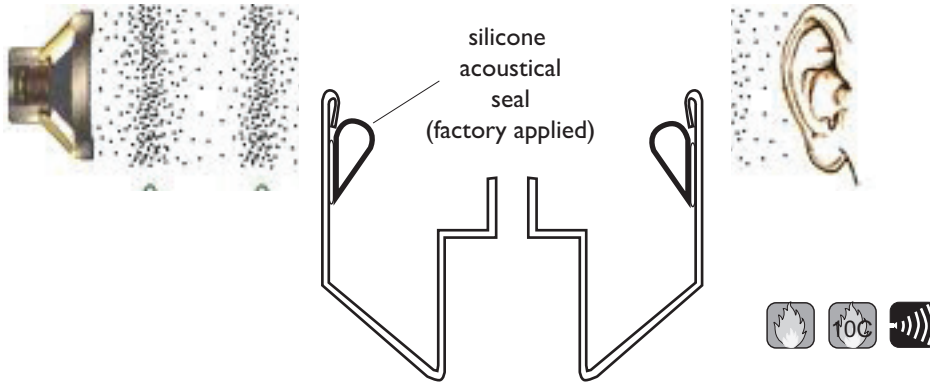

Acoustical Testing performed at Architectural Testing, Inc. to:

ASTM E 90, *Standard Test Method for Laboratory Measurement of Airborne Sound Transmission Loss of Building Partitions.*

ASTM E 413, *Classification for Rating Sound Insulation.*

ASTM E 1338, *Standard Classification for Rating Outdoor-Indoor Sound Attenuation.*

ASTM E 2235, *Standard Test Method for Determination of Decay Rates for Use in Sound Insulation Test Methods.*

STC Ratings:

• SuperLite I-W	STC 28
• Pyran Platinum F	STC 31
• Pyran Platinum L	STC 36
• SuperLite I-20	STC 28
• SuperLite X-90	STC 38
• Wired	STC 28
• Tempered - 1/4"	STC 31
• Insulated Tempered - 1"	STC 35
• Polycarbonate 1/4"	STC 29
• Polycarbonate 1/2"	STC 34
• SuperLite II-XL (45 min.)	STC 40

L-FRA100-SP

Low Profile Lite Kit for Variable Door and/or Glass Thickness

- 18 ga. cold rolled steel
- Mitered and welded corners
- Welded reinforcing clips at corners
- Counter-sunk mounting screw-holes
- #8 Phillips head SMS
- Available in uneven and fractional sizes
- Gray Primer (GPZ) powder coat finish

Required Information

- Specify glass thickness on order
- Specify door thickness on order if other than 1-3/4"

Available Options

- Powder coat color options - see page L2
- Torx Security Screws
- Galvanneal - A40 Steel
- Zinc electro-plating
- Glass & Glazing tape - See Glass Section
- Lead lining - .030" thick

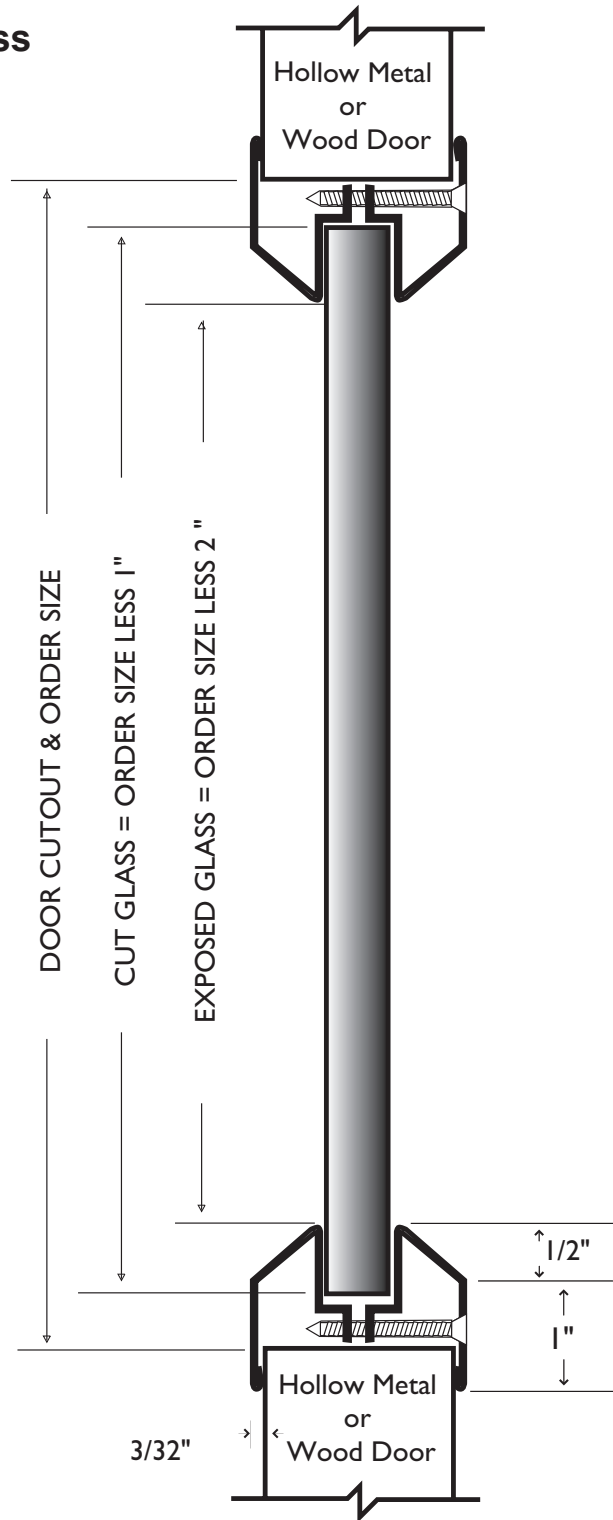

L-FRA100-SP Glass and Door Combinations

Details shown are for 1-3/4" door thickness.
 Only configurations shown are available
 Some applications require thicker glazing tape

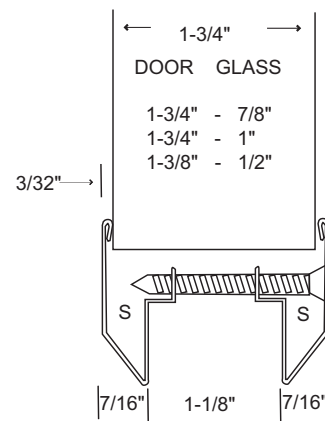
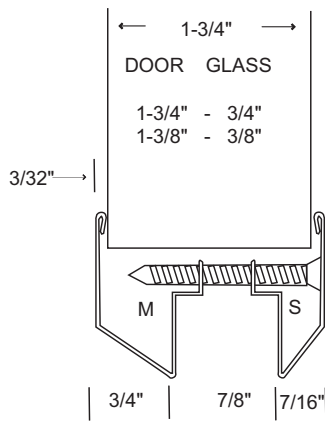
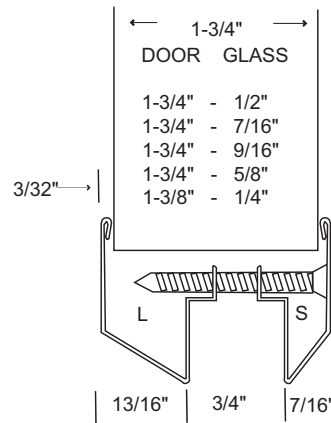
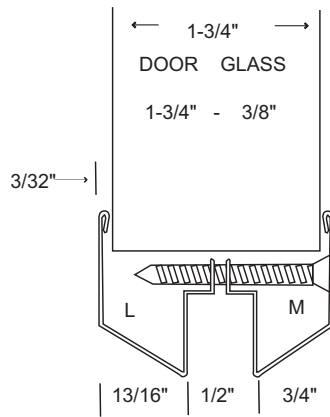

L-GLF100

Square Profile Lite Kit for 1-3/4" Thick Doors and 3/16", 1/4", or 5/16" Glass

- 18 ga. cold rolled steel
- Mitered and welded corners
- Welded reinforcing clips at corners
- Countersunk mounting screw-holes
- #6 x 1-3/4" Phillips Truss Head SMS
- Gray Primer (GPZ) powder coat finish

Available Options

- Powder coat color options - see page L2
- False mullion bars (page L9)
- Torx Security Screws
- Galvanneal - A40 Steel
- Zinc electro-plating
- Glass & Glazing tape - See Glass Section
- Lead lining - .030" thick

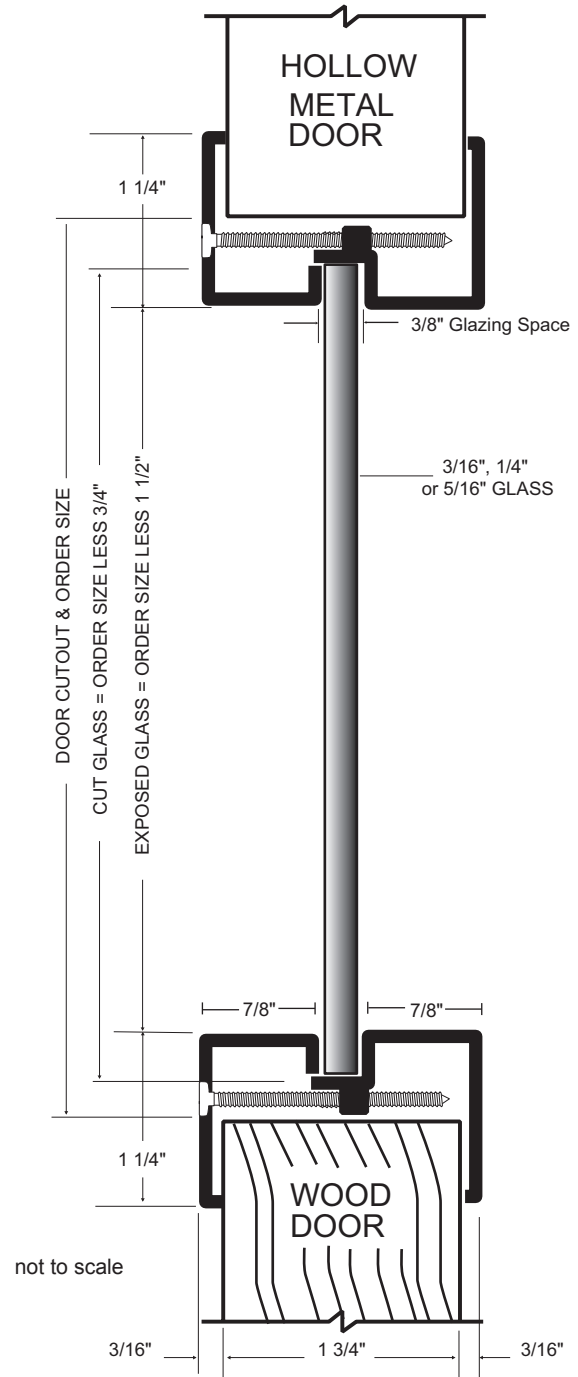
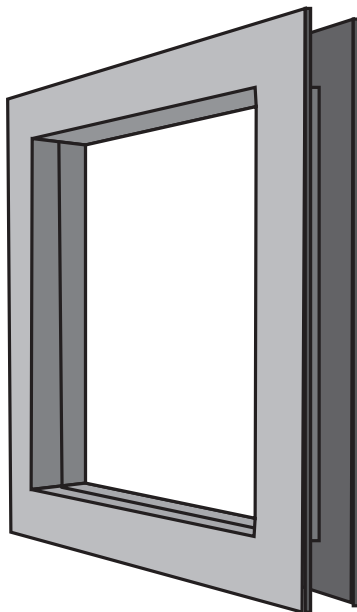

Designed for use on 1-3/4" thick doors manufactured within door industry tolerance of +/- 1/16".

False Mullion Lite Kits

- 1" wide steel channel
- Fits L-GLF100, L-GLF100-SP, L-GLF100-TB, L-GLF100-SP-TB, L-SG100, L-SG100-TB
- Mullion bars welded into both sides of Lite Kit
- Finished to match Lite Kit

Available Options

- * Zinc electro-plating

To Order

Specify Lite Kit x G# (i.e.: G2, G3, G4 etc.)

If other than as illustrated, provide detail & suffix G-SP

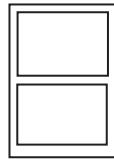
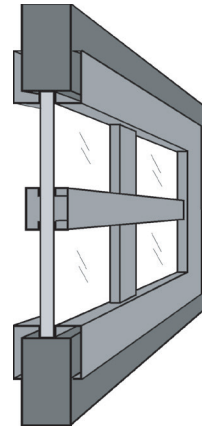

G2
(1 Bar)

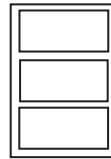

G3
(2 Bars)

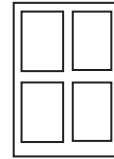

G4
(2 Bars)

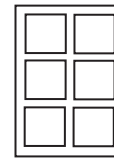

G6
(3 Bars)

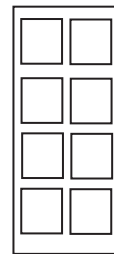

G8
(4 Bars)

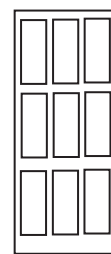

G9
(4 Bars)

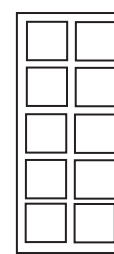

G10
(5 Bars)

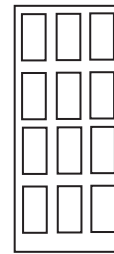

G12
(5 Bars)

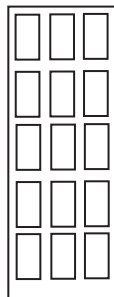

G15
(6 Bars)

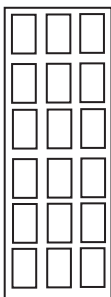

G18
(7 Bars)

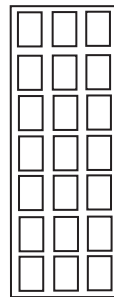

G21
(8 Bars)

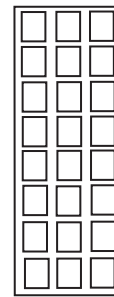

G24
(9 Bars)

L-GLF100-SP

Square Profile Lite Kit for Variable Door and/or Glass Thickness

- 18 ga. cold rolled steel
- Mitered and welded corners
- Welded reinforcing clips at corners
- Countersunk mounting screw-holes
- #6 Phillips Truss Head SMS
- Gray Primer (GPZ) powder coat finish

Required Information

- Specify glass thickness on order
- Specify door thickness on order if other than 1-3/4"

Available Options

- Powder coat color options - see page L2
- False mullion bars (Page L9)
- Torx Security Screws
- Galvanneal - A40 Steel
- Zinc electro-plating
- Glass & Glazing tape - See Glass Section
- Lead lining - .030" thick lead

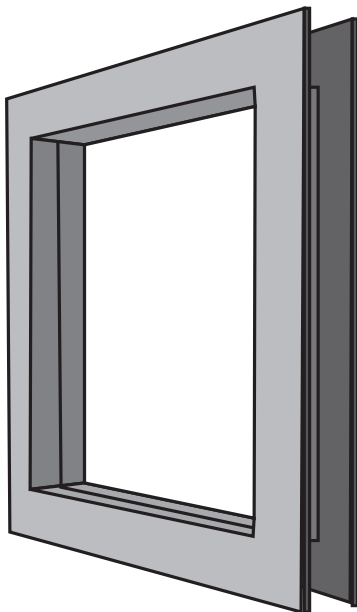

L-GLF100-SP and L-GLF100-SP-TB Glass and Door Combinations

Details shown are for 1-3/4" door thickness
 Only Configurations shown are available
 Some applications require thicker glazing tape
 Thru-bolts available for 1-3/4" thick doors only

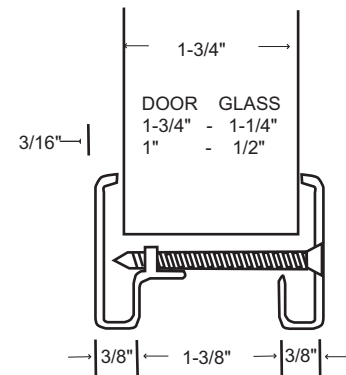
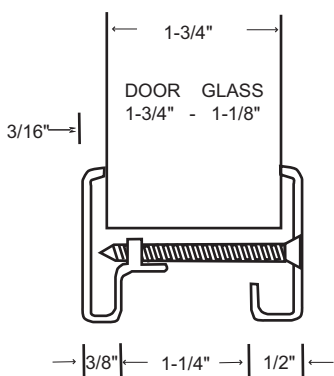
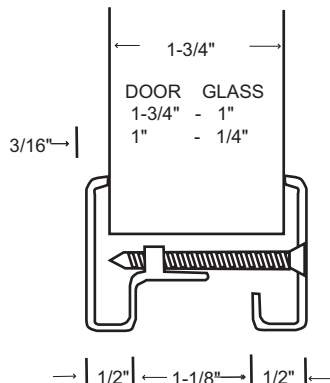
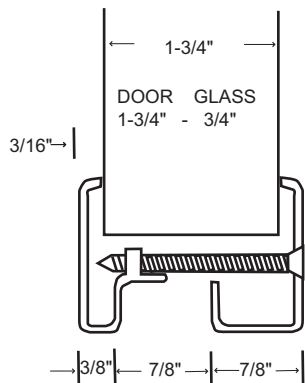
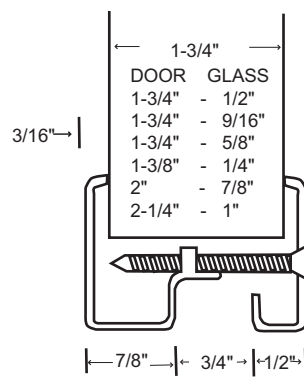
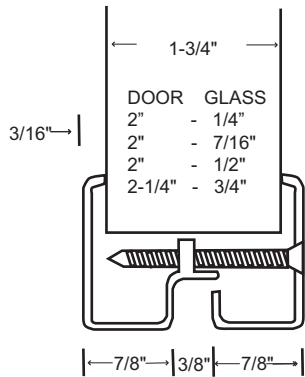

L-GLF100-TB

Thru-bolted Lite Kit for 1-3/4" Thick Doors and 3/16", 1/4", or 5/16" Glass

- 18 ga. cold rolled steel
- Mitered and welded corners
- Welded reinforcing clips at corners
- Countersunk mounting screw-holes
- Thru-bolts for 1-3/4" door
- Gray Primer (GPZ) powder coat finish

Available Options

- Powder coat color options - see page L2
- False Mullion bars (Page L9)
- Torx Security Thru-bolts
- Galvanneal - A40 Steel
- Zinc electro-plating
- Glass & Glazing tape - See Glass Section
- Lead lining - .030" thick



L-GLF100-SP-TB

Thru-bolted Lite Kit for 1-3/4" Thick Doors and Variable Glass Thickness 3/8" to 1-1/4"

- 18 ga. cold rolled steel
- Mitered and welded corners
- Welded reinforcing clips at corners
- Countersunk mounting screw-holes
- Thru-bolts for 1-3/4" door
- Gray Primer (GPZ) Powder coat finish

Required Information: Specify Glass thickness

Available Options

- Powder coat color options - see page L2
- False Mullion bars (Page L9)
- Torx Security Thru-bolts
- Galvanneal - A40 steel
- Zinc electro-plating
- Glass & Glazing tape - See Glass Section
- Lead lining - .030" thick

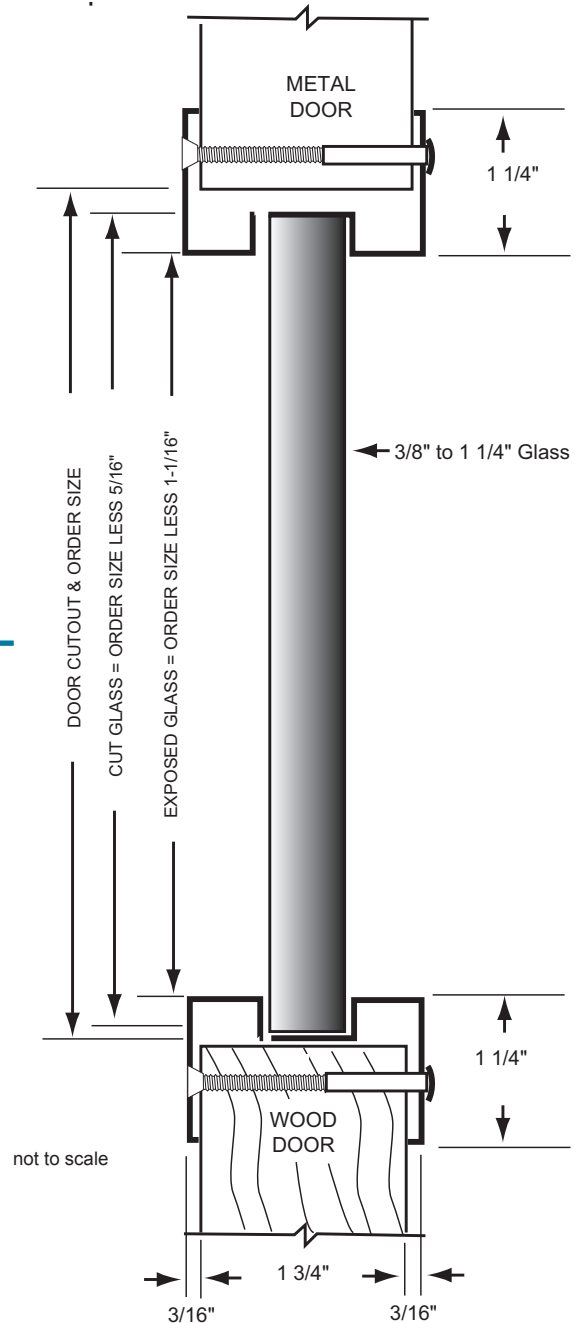

Designed for 1-3/4" thick Doors manufactured within door industry tolerance of +/- 1/16"

L-SG100

Self Attaching Security Grille Lite Kit for Variable Door and/or Glass Thickness

- 18 ga. cold rolled steel
- 16 ga. steel 3/4" x 3/4" security grille welded in both sides
- Mitered and welded corners
- Welded reinforcing clips at corners
- Countersunk mounting screw-holes
- #6 Phillips truss head screws
- Gray Primer (GPZ) powder coat finish

Required Information

- Specify glass thickness on order
- Specify door thickness on order if other than 1-3/4" (See page L15 for available sizes)

Available Options

- Powder coat color options - see page L2
- False mullion bars (Page L9)
- Torx security screws
- Galvanneal - A40 Steel
- Zinc electro-plating
- Glass & glazing tape - See Glass Section
- Lead lining - .030" thick



*up to 90 minutes.

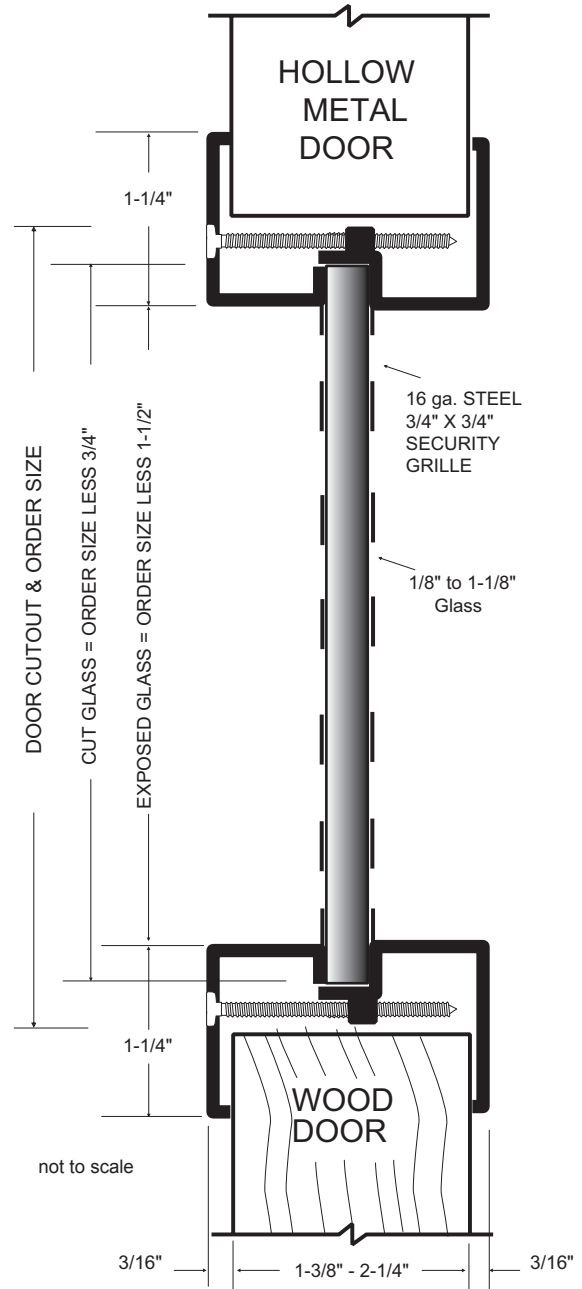
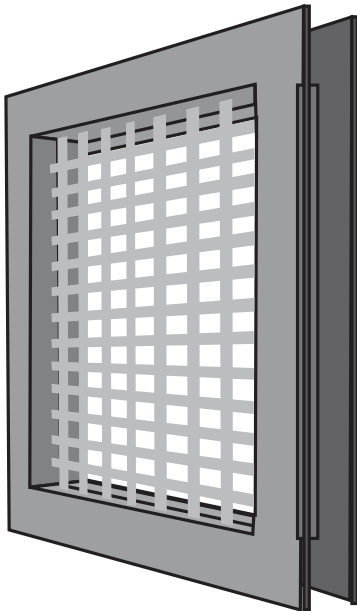

L-SG100-TB

Thru-Bolted Security Grille Lite Kit for 1-3/4" Thick Doors and Variable Glass Thickness

- 18 ga. cold rolled steel
- 16 ga. steel 3/4" x 3/4" security grille welded in both sides
- Mitered and welded corners
- Welded reinforcing clips at corners
- Countersunk mounting screw-holes
- Thru-bolts for 1-3/4" door
- Gray Primer (GPZ) powder coat finish

Required Information;

- Specify glass thickness on order
 (See page L15 for available sizes)

Available Options

- Powder coat color options - see page L2
- False mullion bars (Page L9)
- Torx security Thru-bolts
- Galvanneal - A40 Steel
- Zinc electro-plating
- Glass & Glazing tape - See Glass Section
- Lead lining - .030" thick



*up to 90 minutes.

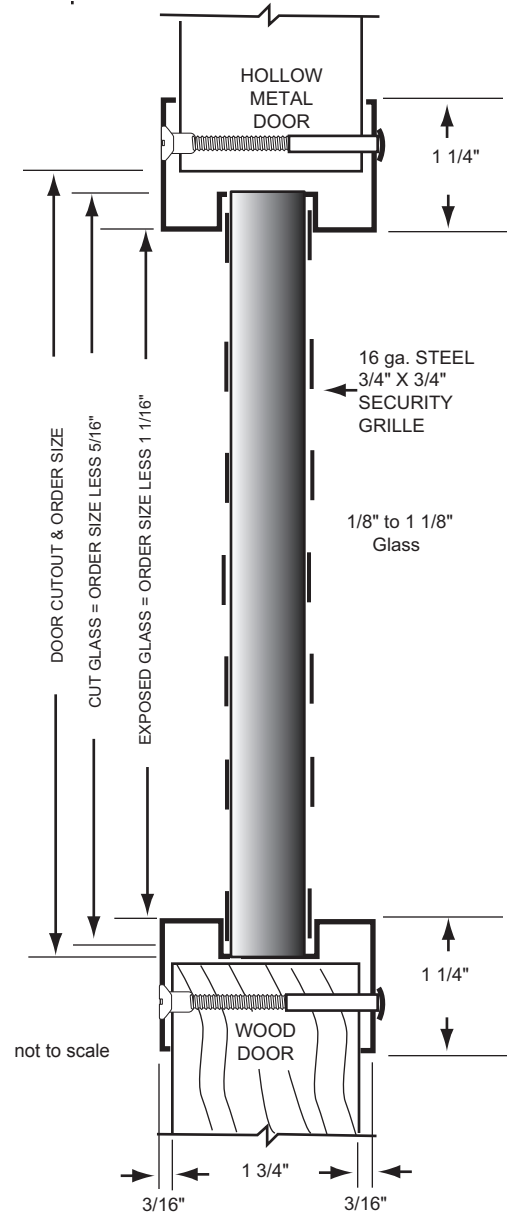
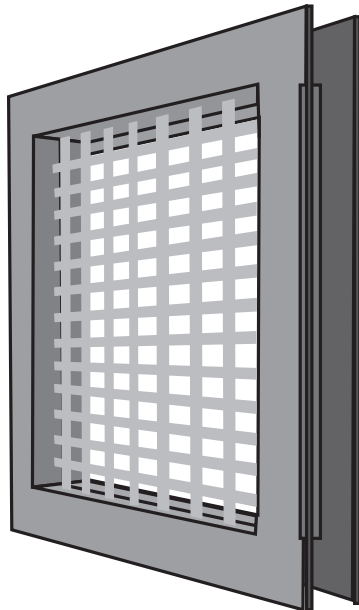

L-SG100 and L-SG100-TB Glass and Door Combinations

Details shown are for 1-3/4" door thickness
 Only Configurations shown are available
 Some applications require thicker glazing tape
 Thru-bolts available for 1-3/4" thick doors only

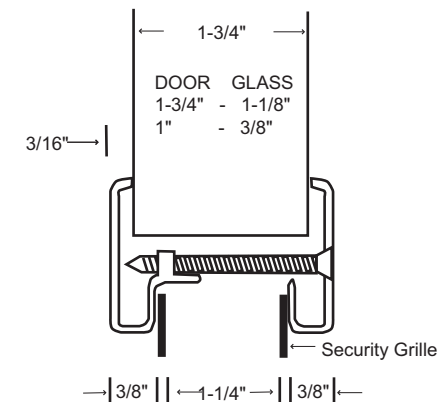
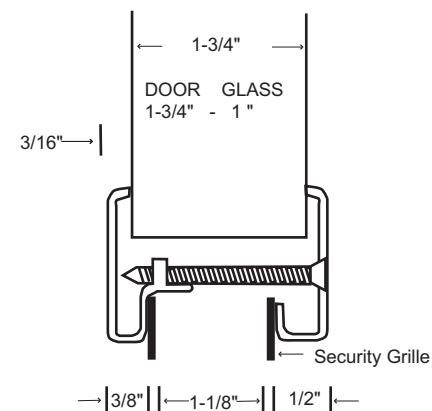
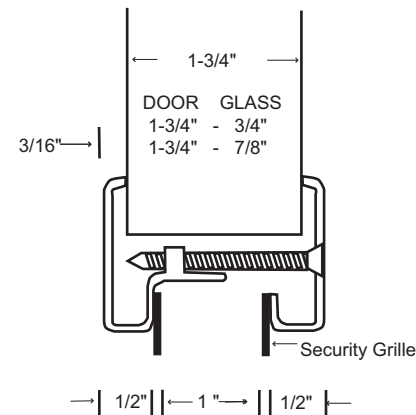
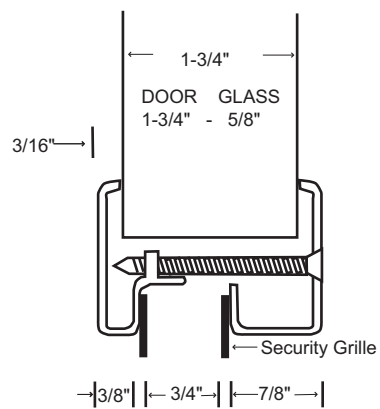
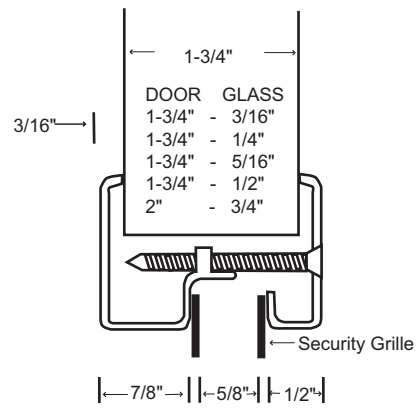
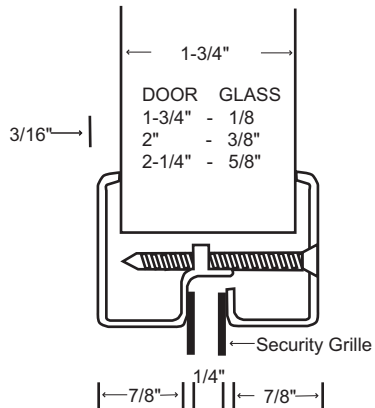

L-CVFM-SS

Stainless Steel Lite Kit for 1-3/4" Thick Doors and 3/16", 1/4", or 5/16" Glass

- 18 ga. Type 304 stainless steel
- Mitered and welded corners
- Countersunk mounting screw-holes
- Available in uneven and fractional sizes
- #8 x 1-3/4" Phillips head SMS
- #4 satin finish

Available Options

- Powder coat finish - see page L2
- Torx Security Screws
- Glass & Glazing tape - See Glass Section
- Lead Lining - .030" thick

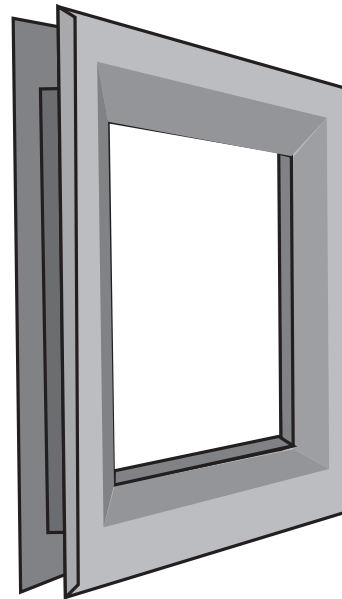
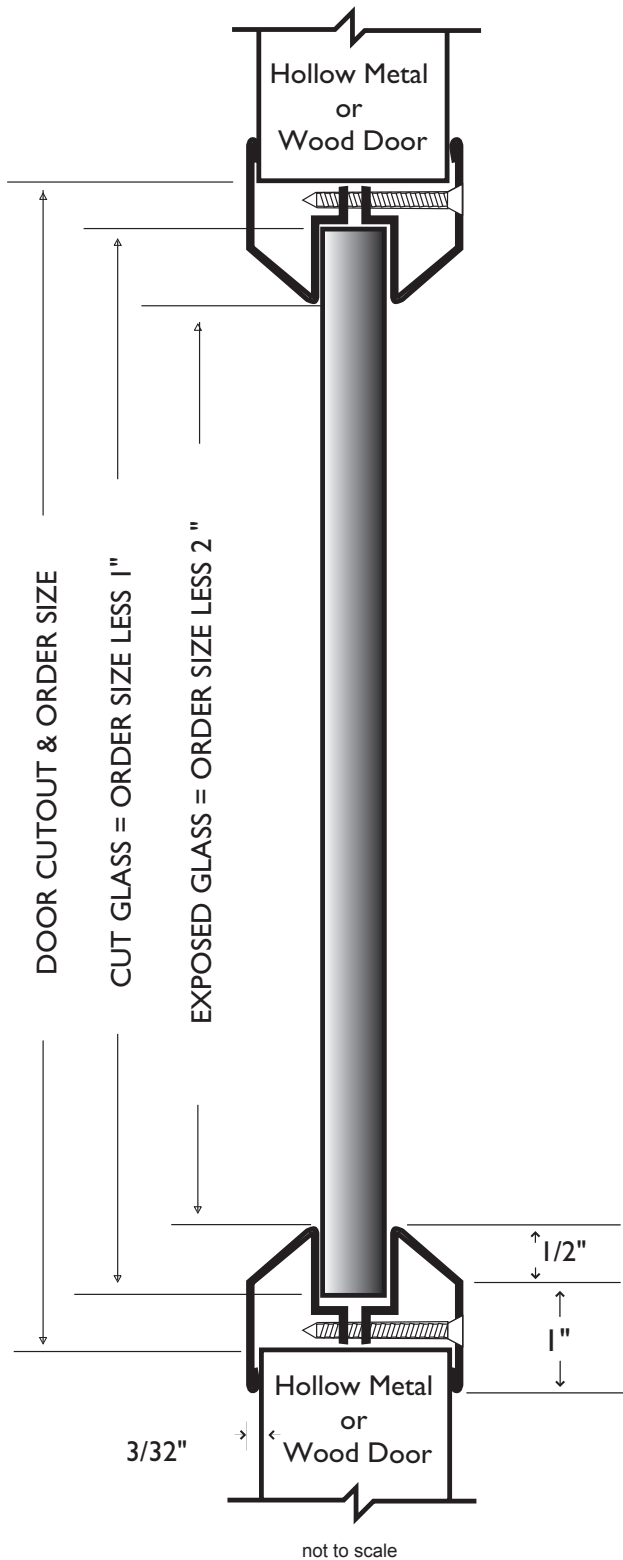

L-FRA100-ALUM

Aluminum Lite Kit for 1-3/4" Thick Doors and 3/16", 1/4" or 5/16" Glass

- .050 extruded aluminum
- Mitered and welded corners
- Welded reinforcing clips at corners
- Counter-sunk mounting screw-holes
- #8 x 1-3/4" Phillips head SMS
- Available in uneven and fractional sizes
- Aluminum Silver (ASL) powder coat finish

Available Options

- Powder coat color options - see page L2
- Torx Security Screws
- Glass & Glazing tape - See Glass Section
- Lead lining - .030" thick

NOT FIRE-RATED

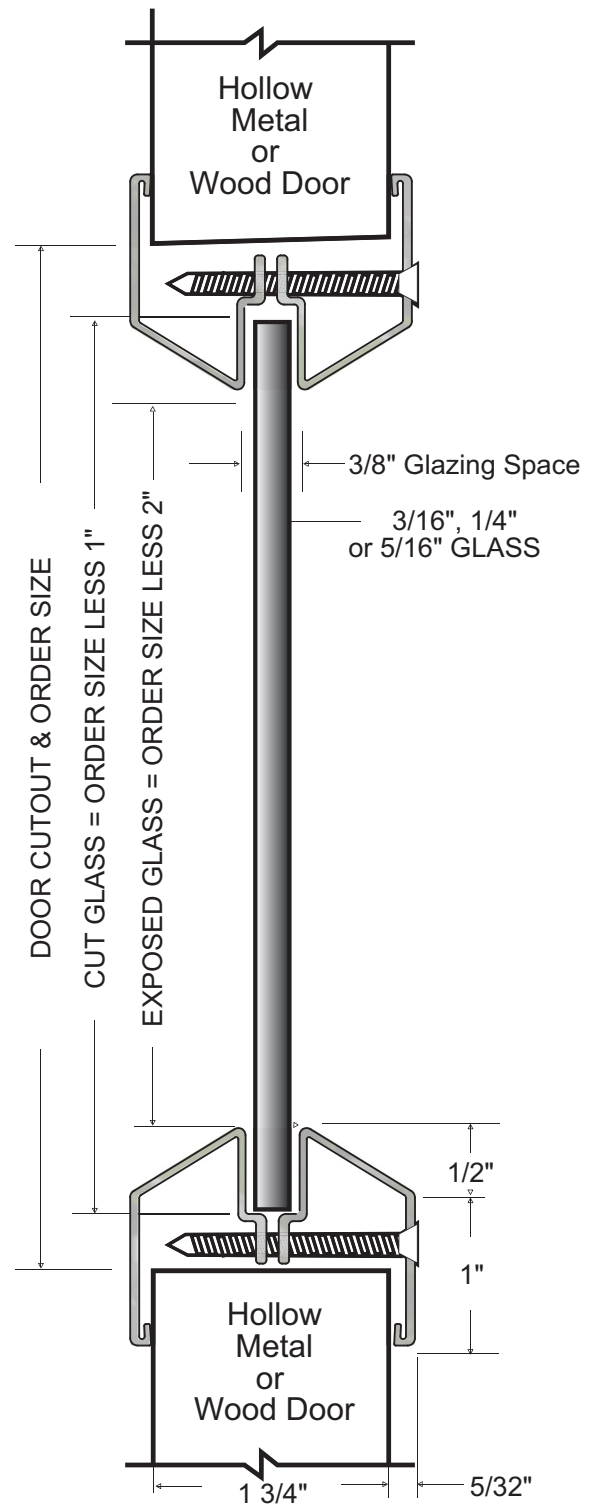

Designed for use on 1-3/4" thick doors manufactured within door industry tolerance of +/- 1/16".



Page
Intentionally
Blank

L-VGLF-WD (9" X 5")

Security Lite Kit

- 18 ga. cold rolled steel
- Mitered and welded corners
- 1-3/4" hollow metal or wood doors
- 1/2" thick high impact polycarbonate plastic
- 18 ga. steel hinged panel
- No exposed fasteners on outside of door
- Low-profile frame
- 6" x 2" exposed glass size
- #8 x 1" Oval head TEK screws
- 2.8 oz. Silicone sealant included
- Gray Primer (GPZ) powder coat finish

Available Options

- Powder coat color options - see page L2
- Torx security screws
- Zinc electro-plating

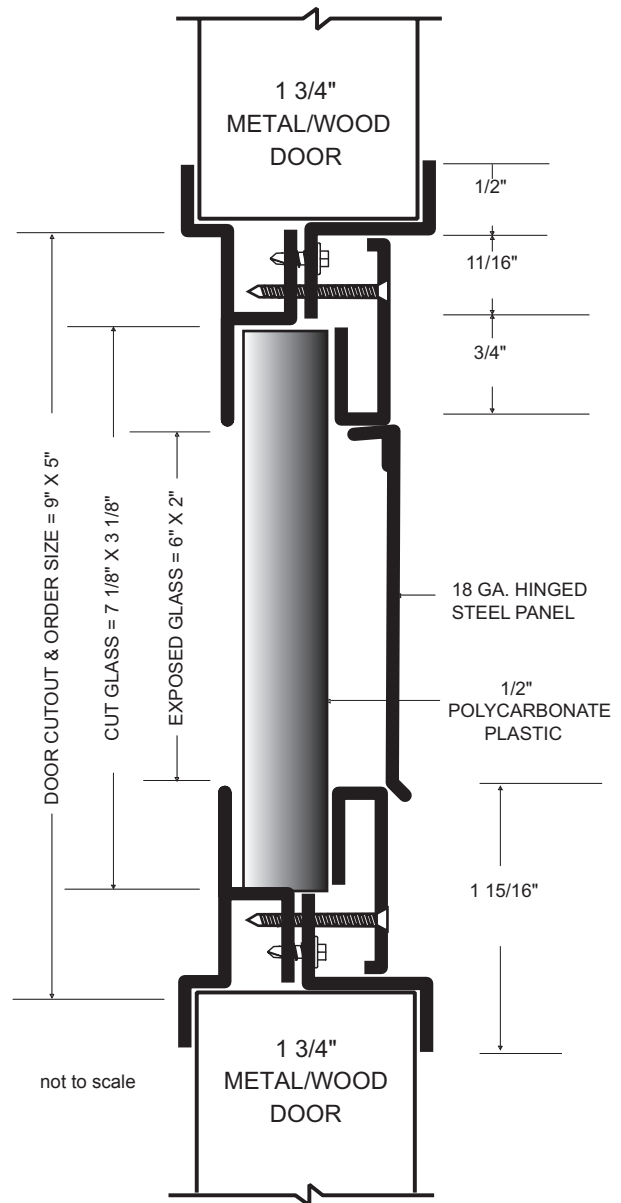

L-VGLF-PZ (9" X 9")

Security Lite Kit

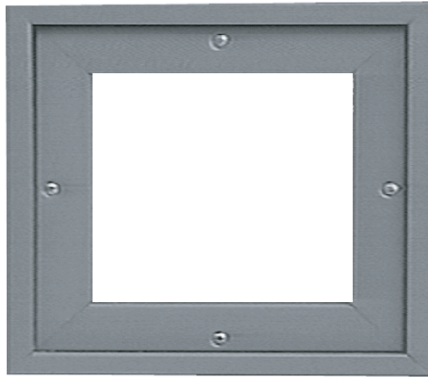

- 18 ga. cold rolled steel
- Mitered and welded corners
- For 1-3/4" hollow metal or wood doors
- 1/2" thick high impact polycarbonate plastic
- No exposed fasteners on outside of door
- Low-profile frame
- 6" x 6" exposed glass size
- #8 x 1" Oval head TEK screws
- 2.8 oz. Silicone sealant included
- Gray Primer (GPZ) powder coat finish

Available Options

- Powder coat color options - see page L2
- Torx security screws
- Zinc electro-plating

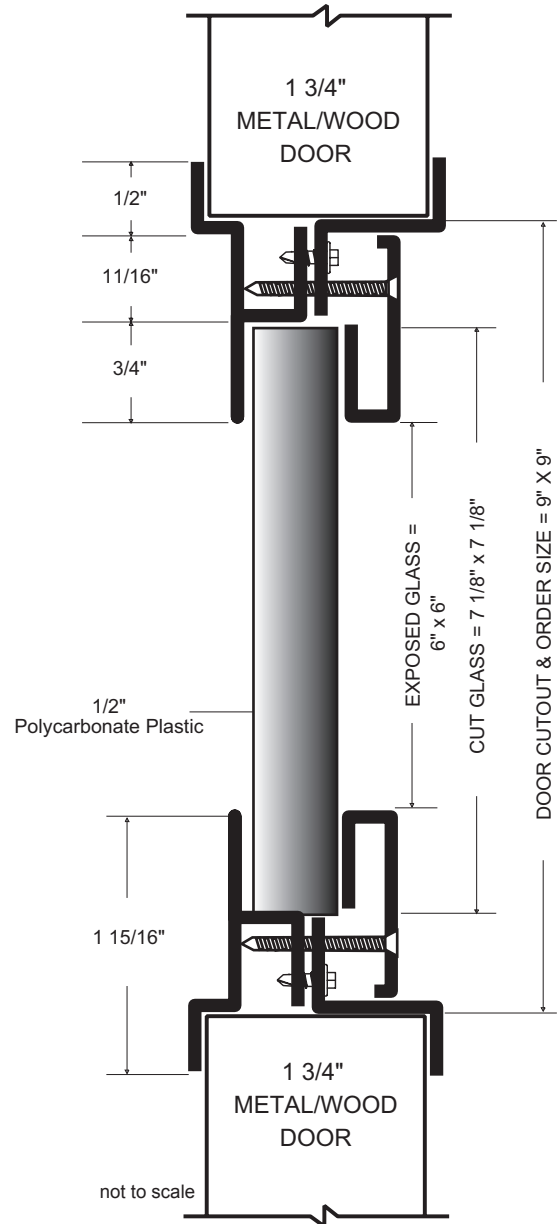

L-VGLF-MD (9" X 9")

L-VGLF-MDL (12" X 12")

Security Lite Kit

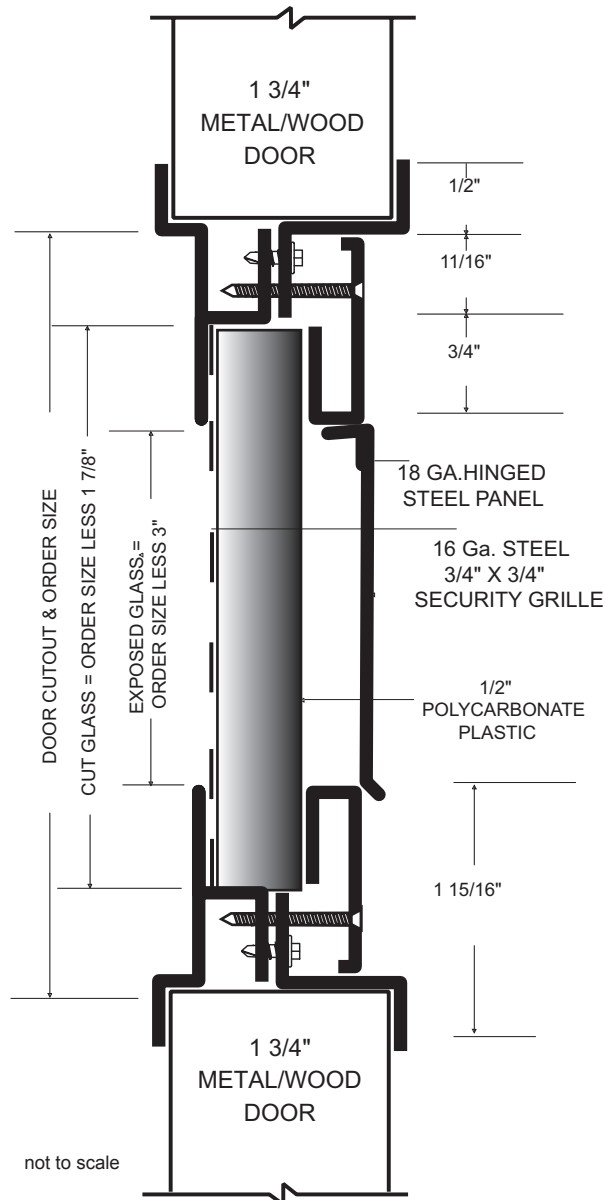

- 18 ga. cold rolled steel
- Mitered and welded corners
- For 1-3/4" hollow metal or wood doors
- 1/2" thick high impact polycarbonate plastic
- 16 ga. steel 3/4" x 3/4" security grille
- 18 ga. steel hinged panel
- No exposed fasteners on outside of door
- Low-profile frame
- 6" x 6" exposed glass size on L-VGLF-MD
- 9" x 9" exposed glass size on L-VGLF-MDL
- #8 x 1" Oval head TEK screws
- 2.8 oz. Silicone sealant included
- Gray Primer (GPZ) powder coat finish

Available Options

- Powder coat color options - see page L2
- Torx security screws
- Zinc electro-plating



L-VGLF-OG (9" X 9")

Security Lite Kit

- 18 ga. cold rolled steel
- Mitered and welded corners
- For 1-3/4" hollow metal or wood doors
- 1/2" thick high impact polycarbonate plastic
- 18 ga. steel hinged panel
- No exposed fasteners on outside of door
- Low-profile frame
- 6" x 6" exposed glass size
- #8 x 1" Oval head TEK screws
- 2.8 oz. Silicone sealant included
- Gray Primer (GPZ) powder coat finish

Available Options

- Powder coat color options - see page L2
- Torx security screws
- Zinc electro-plating



not to scale

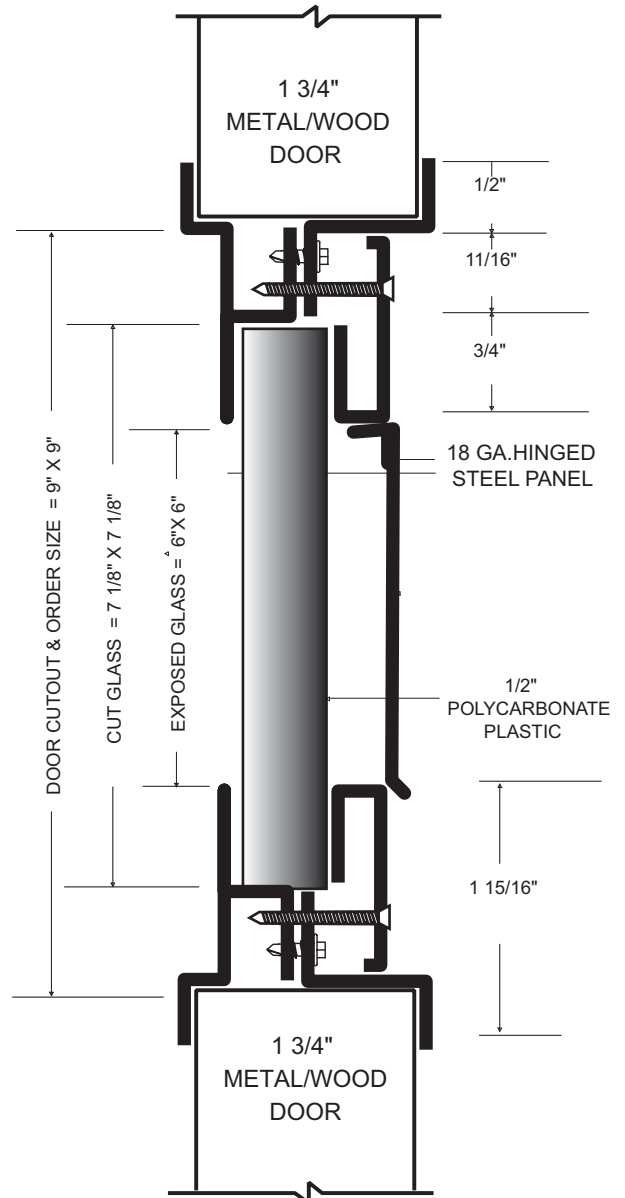

L-VGLF-SF (11" X 11")

Security Lite Kit

- 18 ga. cold rolled steel
- Mitered and welded corners
- For 1-3/4" hollow metal or wood doors
- 1/4" thick high impact polycarbonate plastic
- 16 ga. steel 3/4" x 3/4" security grille
- 18 ga. steel hinged panel with bolt latch
- No exposed fasteners on outside of door
- Low-profile frame
- 8" x 8" exposed glass size
- #8 x 1" Oval head TEK screws
- 2.8 oz. Silicone sealant included
- Gray Primer (GPZ) powder coat finish

Available Options

- Powder coat color options - see page L2
- Torx security screws
- Zinc electro-plating

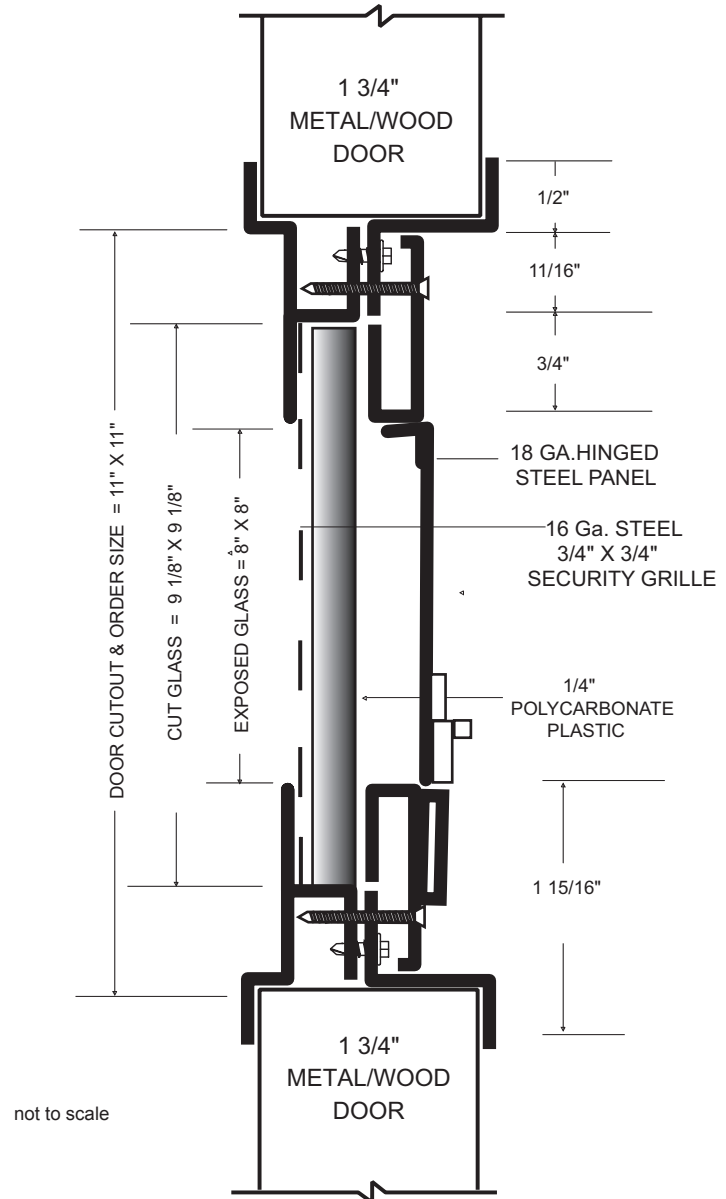
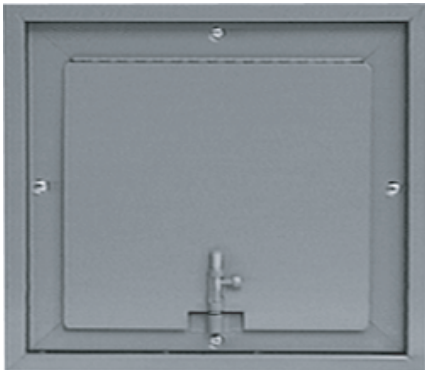

L-FRA-100-RD

Round Lite Kit for 1-3/4" Thick Doors and 3/16", 1/4", or 5/16" Glass

- 18 ga. cold rolled steel
- Countersunk mounting screw-holes
- #8 x 1-3/4" Phillips head SMS
- Gray Primer

Available Options

- Powder coat color options - see page L2
- Torx security screws
- Zinc electro-plating
- Glass & Glazing tape - See Glass Section



- Available in 12", 18" and 24" sizes only

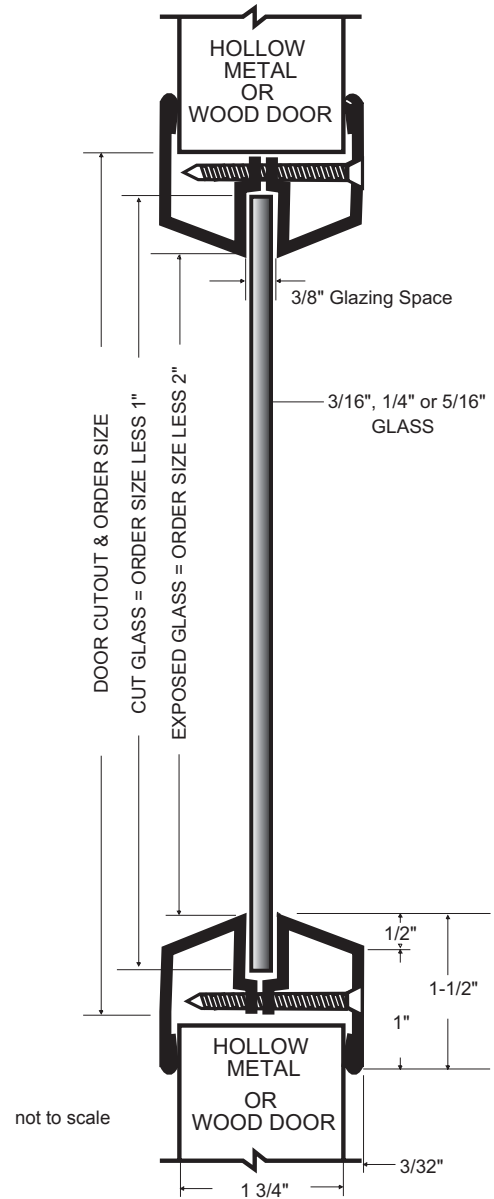
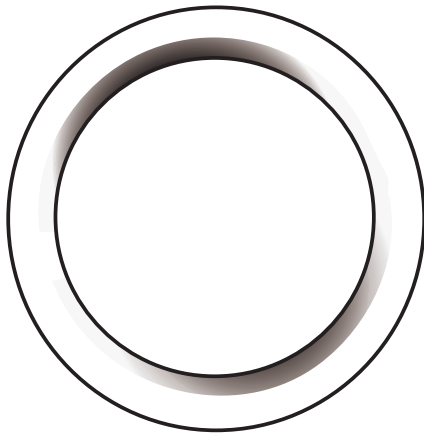

L-700-RX

No Vision Door Louver for 1-3/4" Thick Doors

- 18 ga. cold rolled steel
- Mitered and welded corners
- Welded reinforcing clips at corners
- Inverted "V" design
- Blades 24 ga. steel; hemmed edges
- Counter-sunk mounting screw-holes
- #8 x 3/4" Phillips head SMS
- Available in uneven and fractional sizes
- Free area 55%
- Gray Primer (GPZ) powder coat finish

Available Options

- Powder coat color options - see page L2
- Thru Bolts - specify L-700-RX-TB
- Aluminum Insect screen - 22 ga. 1/8" square mesh installed exterior side unless requested otherwise
- Torx Security Screws
- Galvanneal - A40 Steel
- Zinc electro-plating (not available on insect screen)

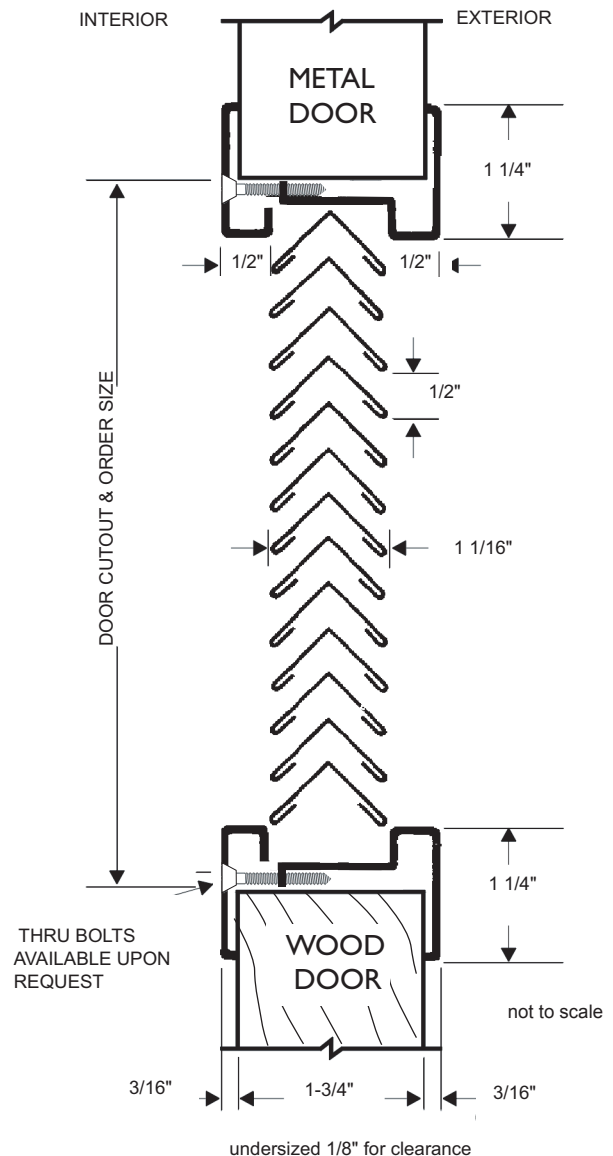

Designed for use on 1-3/4" thick doors manufactured within door industry tolerance of +/- 1/16".

L-700 SERIES

No Vision Door and Partition Louver for 1-3/8", 1-3/4" up to 2-1/4" Thick Doors

- 20 ga. cold rolled steel frame
- Mitered and welded corners
- Welded reinforcing clips at corners
- Inverted "V" design
- Blades 24 ga. steel; hemmed edges
- Counter-sunk mounting screw-holes
- #8 x 3/4" Phillips head SMS
- Available in uneven and fractional sizes
- Gray Primer (GPZ) powder coat finish
- Free area 55%

Available Options

- Powder coat color options - see page L2
- Thru bolts (TB) for 1-3/4" thick doors
- Aluminum Insect screen - 22 ga. 1/8" square mesh installed exterior side unless requested otherwise
- Torx Security Screws
- Galvanneal A40 Steel
- Zinc electro-plating (not available on insect screen)

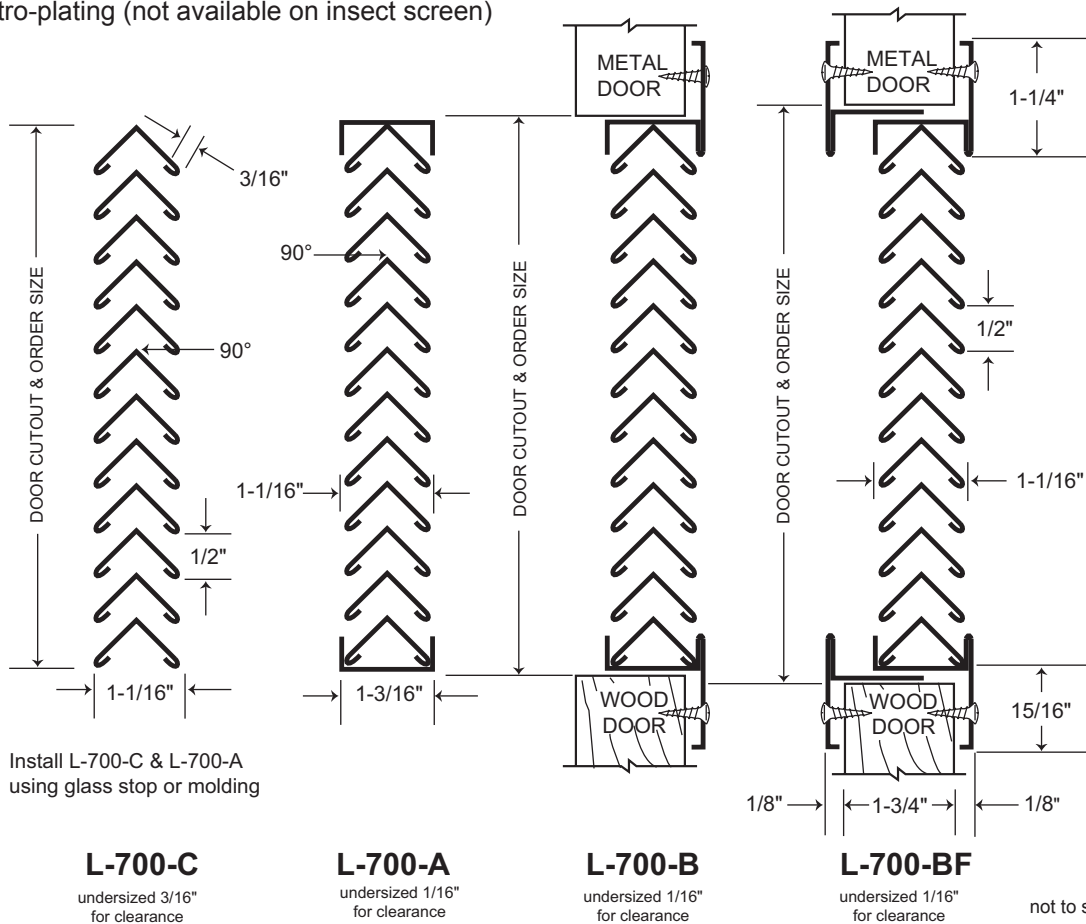
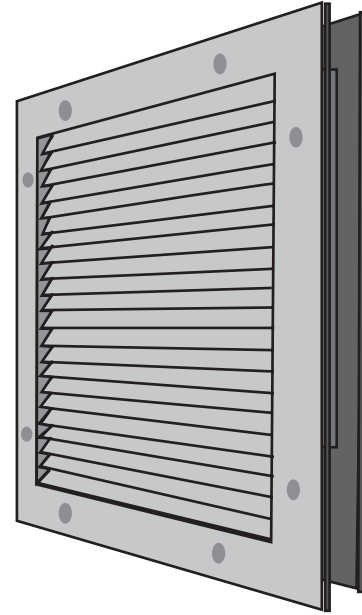

L-A700 SERIES

Aluminum No Vision Door and Partition Louver for 1-3/8", 1-3/4" up to 2-1/4" Thick Doors

- Frame .050" extruded aluminum
- Blades .050" extruded aluminum
- Mitered corners secured with reinforcing clips
- Inverted "V" design
- Counter-sunk mounting screw-holes
- #8 x 3/4" Phillips head SMS
- Available in uneven and fractional sizes
- Aluminum Silver (ASL) powder coat finish
- Free area 55%

Available Options

- Powder coat color options - see page L2
- For exterior use specify drainage weep holes
- Thru bolts (TB) for 1-3/4" door when specified
- Aluminum Insect screen - 22 ga. 1/8" square mesh installed exterior side unless requested otherwise
- Torx Security Screws

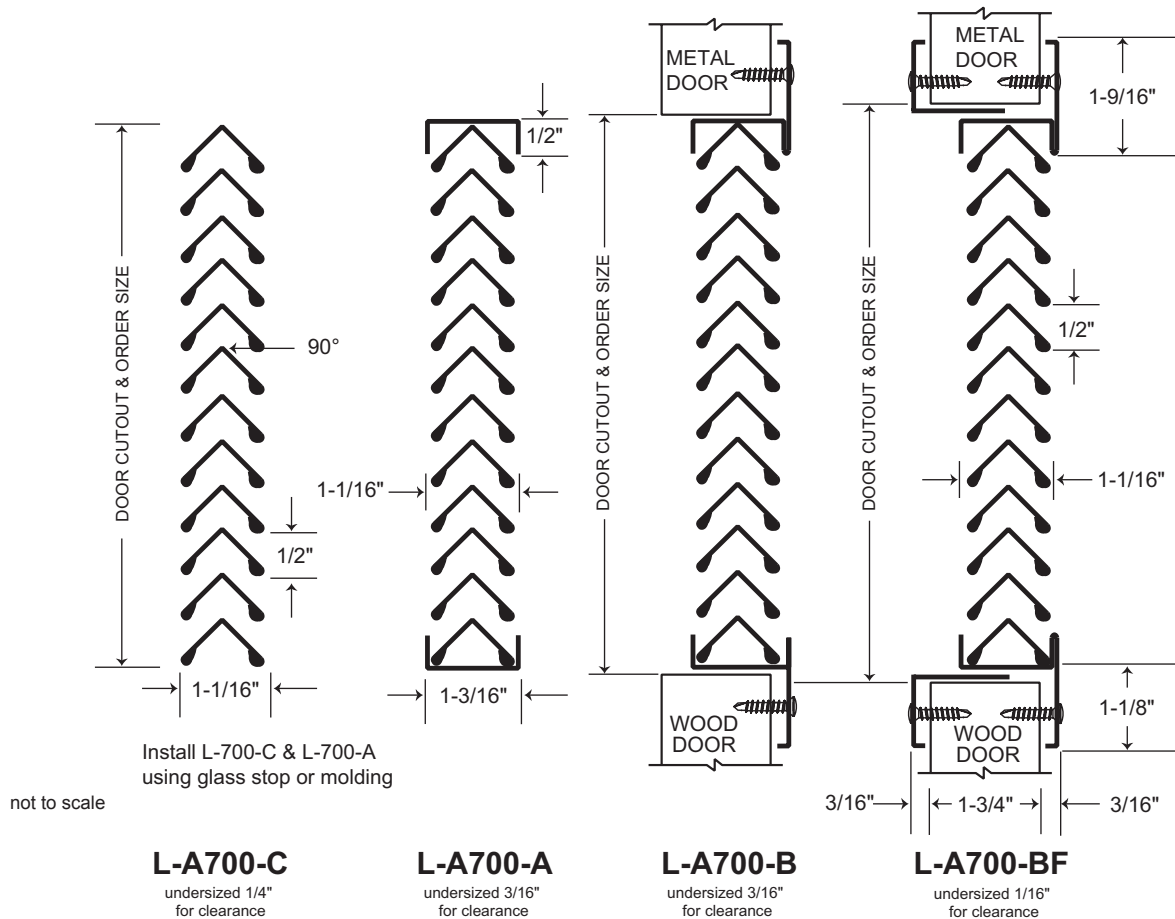
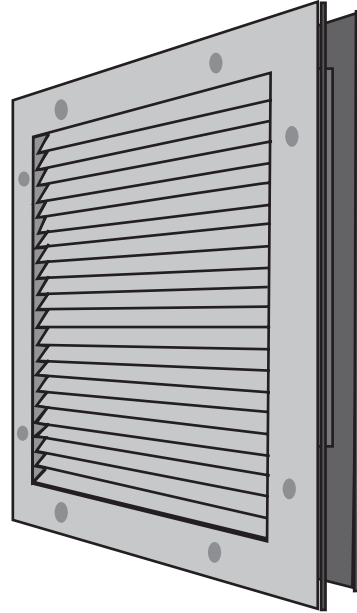

L-1900

Fire-rated Fusible Link Louver for 1-3/4" Thick Doors up to 90 minutes

- Blades close when activated by fire/heat
- 18 ga. cold rolled steel frame
- 18 ga. cold rolled steel adjustable "Z" blades
- Mitered corners secured with reinforcing clips
- Stainless Steel Spring
- 165° Fusible link
- Free area 40%
- #8 x 3/4" Phillips head SMS
- Gray Primer (GPZ) powder coat finish

Available Options

- Aluminum insect screen - 22 ga. 1/8" square mesh installed on exterior side unless requested otherwise
- Torx Security screws
- Galvanneal A40 steel



*up to 90 minutes

Size Information:
Available in whole inch increments
Minimum size: 10" x 6"
Maximum size: 24" x 30"

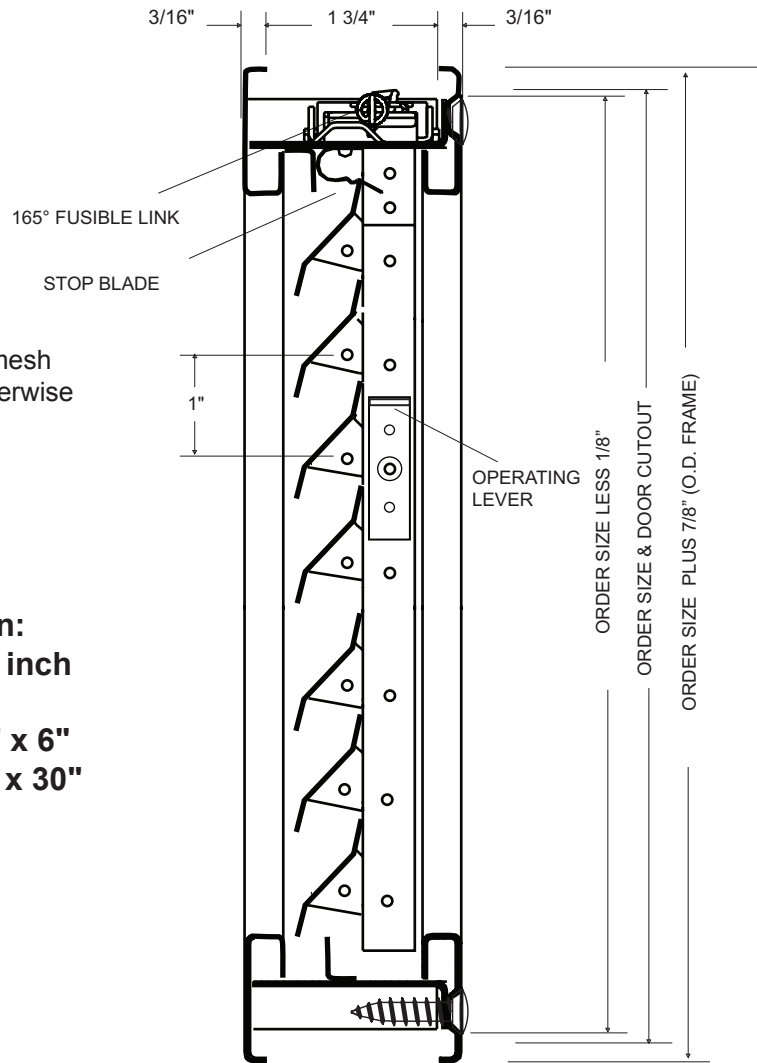

undersized 1/8" for clearance

not to scale

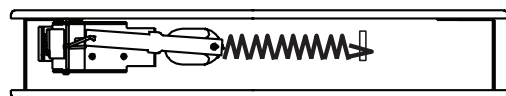

top view fusible link mechanism

L-1800

Adjustable Blade Louver for 1-3/4" Thick Doors

- Manually adjustable blades
- 18 ga. cold rolled steel frame
- 18 ga. cold rolled steel adjustable "Z" blades
- Mitered corners secured with reinforcing clips
- Free area 40%
- #8 x 3/4" Phillips head SMS
- Gray Primer (GPZ) powder coat finish

Available Options

- Aluminum insect screen - 22 ga. 1/8" square mesh installed on exterior side unless requested otherwise
- Torx Security screws
- Galvanneal A40 steel

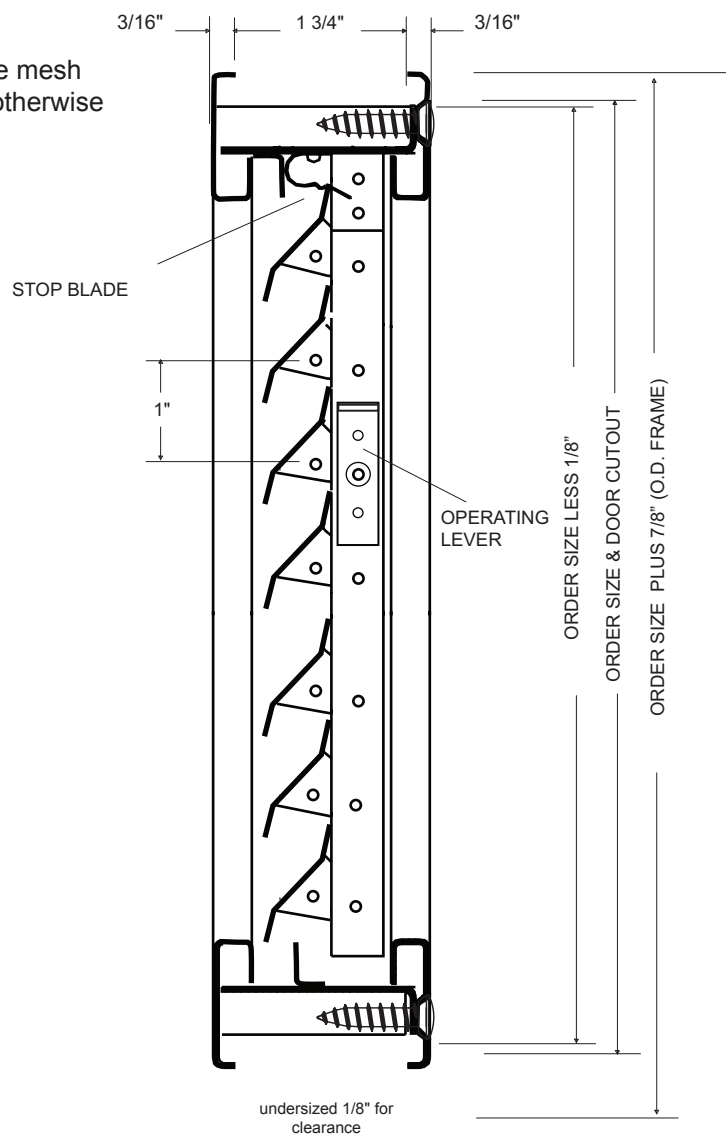

not to scale

Size Information:
Available in whole inch
increments
Minimum size: 10" x 6"
Maximum size: 24" x 30"

L-VRSG-2, L-VRSG-3

Vandal Resistant Security Louver for 1-3/4" Thick Doors

- 18 ga. cold rolled steel frame
- Mitered and welded corners
- Welded reinforcing clips at corners
- Inverted "V" design
- Blades 24 ga. steel, hemmed edges
- 16 ga. steel, 3/4" x 3/4" security grille
- #6 x1-3/4" Phillips Truss Head SMS
- Gray Primer (GPZ) powder coat finish
- Free area 45%

Available Options

- Powder coat color options - see page L2
- Thru bolts (TB) for 1-3/4" thick doors
- Aluminum Insect screen - 22 ga. 1/8" square mesh installed exterior side unless requested otherwise
- Torx Security Screws
- Galvanneal - A40 Steel
- Zinc Electro-plating (not available on insect screen)

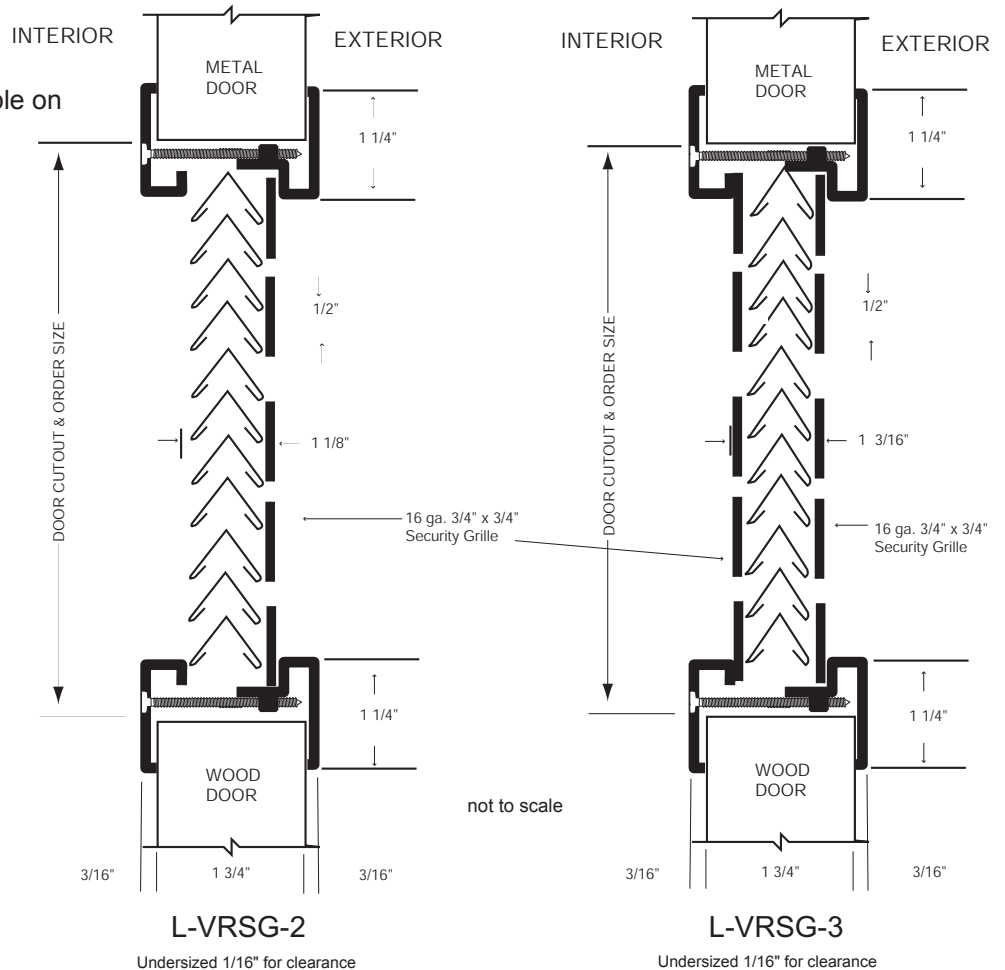
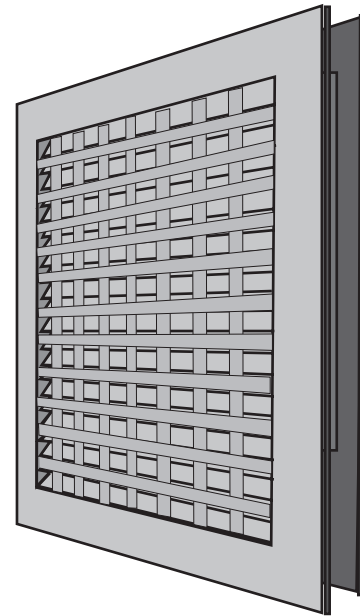

L-75 SERIES

Darkroom Louver for 1-3/4" up to 2-1/4" Thick Doors

- 20 ga. cold rolled steel frame
- Mitered and welded corners
- Welded reinforcing clips at corners
- Blades .040" aluminum
- Counter-sunk mounting screw holes
- #8 x 3/4" Phillips head TEK screws
- Available in uneven and fractional sizes
- Free area 55%
- Textured Black (TBL) powder coat finish

Available Options

- Powder coat color options - see page L2
- Thru Bolts (TB) for 1- 3/4" thick doors
- Aluminum Insect screen - 22 ga. 1/8" square mesh installed exterior side unless requested otherwise
- Torx Security Screws
- Zinc electro-plating (not available on insect screen)

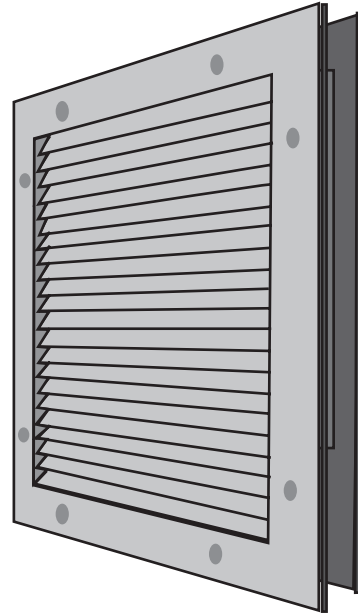

Install L-75-A using glass stop or molding

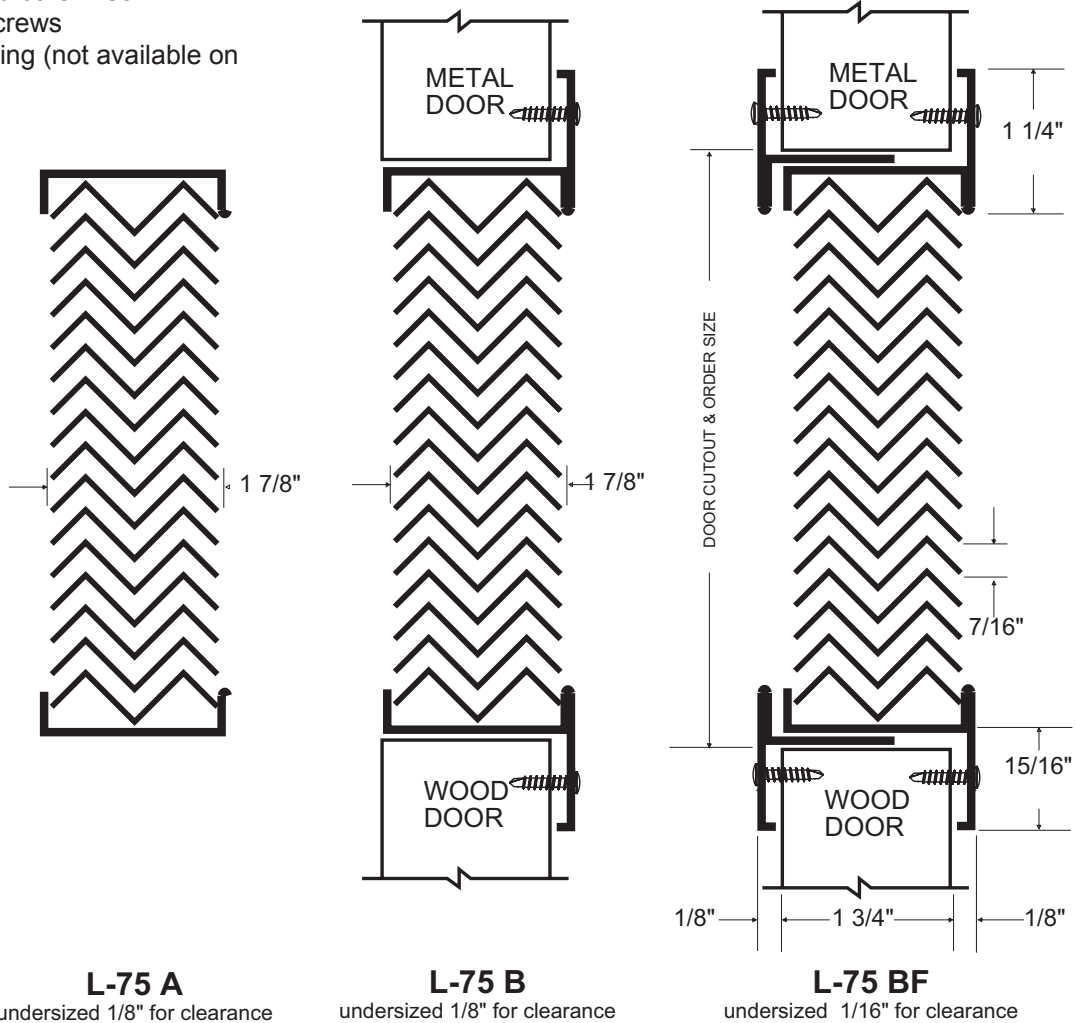

L-Clips

For Optional Reinforcement of 1-3/4" Hollow Metal Doors

- 20 ga. steel
- 4" length clip
- For spot reinforcement of cut-outs in hollow metal doors



NGP Lite Kits on Fire-rated Hollow metal doors do NOT require L-clips or channels welded in the doors.

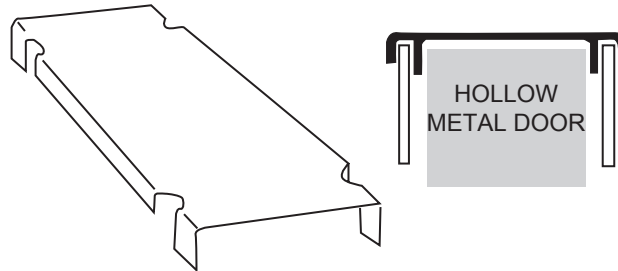

Fasteners for Lites and Louvers



PHILLIPS HEAD
TOP VIEW



TORX SECURITY
TOP VIEW



HEX HEAD WASHER
TOP VIEW

OH = OVAL HEAD TYPE
U/C = UNDERCUT
TH = TRUSS HEAD TYPE
SMS = SHEET METAL SCREW
TB = THRU BOLT
HW = HEX HEAD WASHER

#8 OH PHILLIPS U/C SMS
410 S/S MATERIAL
LENGTHS = 1-1/4", 1-3/4"



WORKS WITH;
L-FRA100, L-FRA100-SP,
L-FRA100-RD, L-CVFM-SS

#6 TH PHILLIPS SMS
410 SS MATERIAL
LENGTHS = 1", 1-3/4"



WORKS WITH;
L-GLF100, L-GLF100-SP
L-SG100

#8 X 32 THRU-BOLT
410 S/S MATERIAL

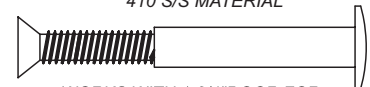

WORKS WITH 1-3/4" DOOR FOR;
L-GLF100-TB, L-GLF100-SP-TB
L-SG100-TB AND THRU
BOLTED LOUVERS

#8 X 3/4" OH
PHILLIPS U/C SMS
410 SS MATERIAL

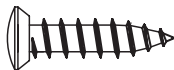

WORKS WITH;
L-700-RX, L-700-SERIES, L-A700-SERIES

#8 X 3/4" PH
PHILLIPS 410SS
SMS

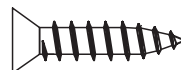

WORKS WITH;
L-1800, L-1900

#8 X 1/2" HW
TEK ZINC SCREW



#8 X 1" OH PHILLIPS
TEK ZINC SCREW



WORKS WITH 1-3/4" DOOR FOR;
L-VGLF-WD, L-VGLF-PZ, L-VGLF-MD,
L-VGLF-MDL, L-VGLF-OG, L-VGLF-SF